



SPARE PARTS LISTING SHEET FOR

# 200mm 250W 230V Two Wheel Bandsaw

Stock No.82756

Part No.BS200B

KEY No.	PART No.	STOCK No.	DESCRIPTION
1	YBS200B-01	85367	Worktable
2	YBS200B-02	85368	Hex screw
3	YBS200B-03	85369	Blade guard
4	YBS200B-04	85370	Plate
5	YBS200B-05	85371	Clamping nut
6	YBS200B-06	85372	Table bracket
7	YBS200B-07	85373	Washer
8	YBS200B-08	85374	Nut
9	YBS200B-09	85376	Locking plate
10	YBS200B-10	85377	Screw
11	YBS200B-11	85378	Spring
12	YBS200B-12	85379	Washer
13	YBS200B-13	85380	Parallel fence
14	YBS200B-14	85384	Bolt
15	YBS200B-15	85385	Serrated washer
16	YBS200B-16	85386	Frame
17	YBS200B-17	85387	Washer
18	YBS200B-18	85388	Sliding seat
19	YBS200B-19	85389	Washer
20	YBS200B-20	85390	Locknut
21	YBS200B-21	85391	Spring pins
22	YBS200B-22	85392	Locking handle
23	YBS200B-23	85393	Fixed slide block
24	YBS200B-24	85394	Lifting gear
25	YBS200B-25	85395	Square neck bolts
26	YBS200B-26	85396	Pan head screw
27	YBS200B-27	85397	Stopper plate
28	YBS200B-28	85398	Lifting rack
29	YBS200B-29	85399	Flexible pin
30	YBS200B-30	85400	The guard bar
31	YBS200B-31	85401	Hex screw
32	YBS200B-32	85402	Connecting pin
33	YBS200B-33	85403	Fixed block
34	YBS200B-34	85404	Clamping pin
35	YBS200B-35	85405	Bearing pin
36	YBS200B-36	85406	625ZZ bearing

KEY No.	PART No.	STOCK No.	DESCRIPTION
37	YBS200B-37	85407	Clamping block
38	YBS200B-38	85408	Plastic partition
39	YBS200B-39	85409	Locknut
40	YBS200B-40	85412	Under clamp pin
41	YBS200B-41	85413	Under clamp block
42	YBS200B-42	85414	Washer
43	YBS200B-43	85415	Shells pad
44	YBS200B-44	85416	Drive wheel
45	YBS200B-45	85417	Flat key
46	YBS200B-46	85418	Washer
47	YBS200B-47	85419	Bolt
48	YBS200B-48	85420	Washer
49	YBS200B-49	85421	Cross screw
50	YBS200B-50	85422	Bolt
51	YBS200B-51	85423	Lower door
52	YBS200B-52	85424	Catch
53	YBS200B-53	85425	Washer
54	YBS200B-54	85426	Door pin
55	YBS200B-55	85427	Upper door
56	Contact Draper	N/A	Saw
57	YBS200B-57	85458	Clip
58	YBS200B-58	85429	6000Z bearing
59	YBS200B-59	85430	C clip
60	YBS200B-60	85431	Driven wheel
61	YBS200B-61	85432	Bolts
62	YBS200B-62	85433	Brush
63	YBS200B-63	85434	Bolts
64	YBS200B-64	85435	Cross screw
65	YBS200B-65	85436	On/off switch
66	YBS200B-66	85437	Shaft collar
67	YBS200B-67	85438	Passive axle
68	YBS200B-68	85439	Adjusting lever
69	YBS200B-69	85440	Axis fixed tube
70	YBS200B-70	85441	Nut
71	YBS200B-71	85442	Fixed seat
72	YBS200B-72	85443	Box nut

**Helpline: (023) 8049 4344. Sales Desk: (023) 8049 4333. General Enquiries: (023) 8026 6355.**

DRAPER TOOLS LTD, HURSLEY ROAD, CHANDLER'S FORD, EASTLEIGH, HANTS. SO53 1YF. U.K website: [www.drapertools.com](http://www.drapertools.com) e-mail: [sales@drapertools.com](mailto:sales@drapertools.com)



SPARE PARTS LISTING SHEET FOR  
**200mm 250W**  
**230V Two Wheel Bandsaw**  
Stock No.82756 Part No.BS200B

KEY No.	PART No.	STOCK No.	DESCRIPTION
73	YBS200B-73	85444	Adjust bracket
74	YBS200B-74	85445	Column plug
75	YBS200B-75	85446	Handwheel lock
76	YBS200B-76	85447	Nut
77	YBS200B-77	85448	Stud
78	YBS200B-78	85449	Cover
79	YBS200B-79	85450	Bolt
80	YBS200B-80	85451	Plastic screws
81	YBS200B-81	85452	Plastic nut
82	YBS200B-82	85453	Lifting knob
83	YBS200B-83	85454	Knob
84	YBS200B-84	85455	Spring hat
85	YBS200B-85	85456	Spring
86	YBS200B-86	85457	Washer
87	YBS200B-87	85458	Bolt
88	YBS200B-88	85459	Blade protector
90	YBS200B-89	85460	Extraction port
91	YBS200B-90	85462	Motor
92	YBS200B-91	85463	Plate

KEY No.	PART No.	STOCK No.	DESCRIPTION
93	YBS200B-92	85464	Handle
94	YBS200B-93	85466	Pulley tyres
95	YBS200B-94	85468	Scale
96	YBS200B-95	85469	Scale
97	YBS200B-96	85470	Mitre gauge
98	YBS200B-97	85471	Ø8 toothed washer
99	YBS200B-98	85472	Spring washer
100	YBS200B-99	85473	Wiring buckle
101	YBS200B-100	85474	Ø4 toothed washer
102	YBS200B-101	85475	Bolt
103	YBS200B-102	85476	Cable protector
104	YBS200B-103	85477	Motor lead wire
105	YBS200B-104	85478	Cable protector
106	YBS200B-105	85479	Cable and plug
107	YBS200B-106	85480	Fixed pole plate
108	YBS200B-107	85481	Nut
109	YBS200B-108	85482	Cross head screw
110	YBS200B-109	85483	Distance sleeve

**Helpline: (023) 8049 4344. Sales Desk: (023) 8049 4333. General Enquiries: (023) 8026 6355.**

DRAPER TOOLS LTD, HURSLEY ROAD, CHANDLER'S FORD, EASTLEIGH, HANTS. SO53 1YF. U.K website: [www.drapertools.com](http://www.drapertools.com) e-mail: [sales@drapertools.com](mailto:sales@drapertools.com)



# SPARE PARTS DRAWING SHEET FOR 200mm 250W 230V Two Wheel Bandsaw

Stock No.82756

Part No.BS200B

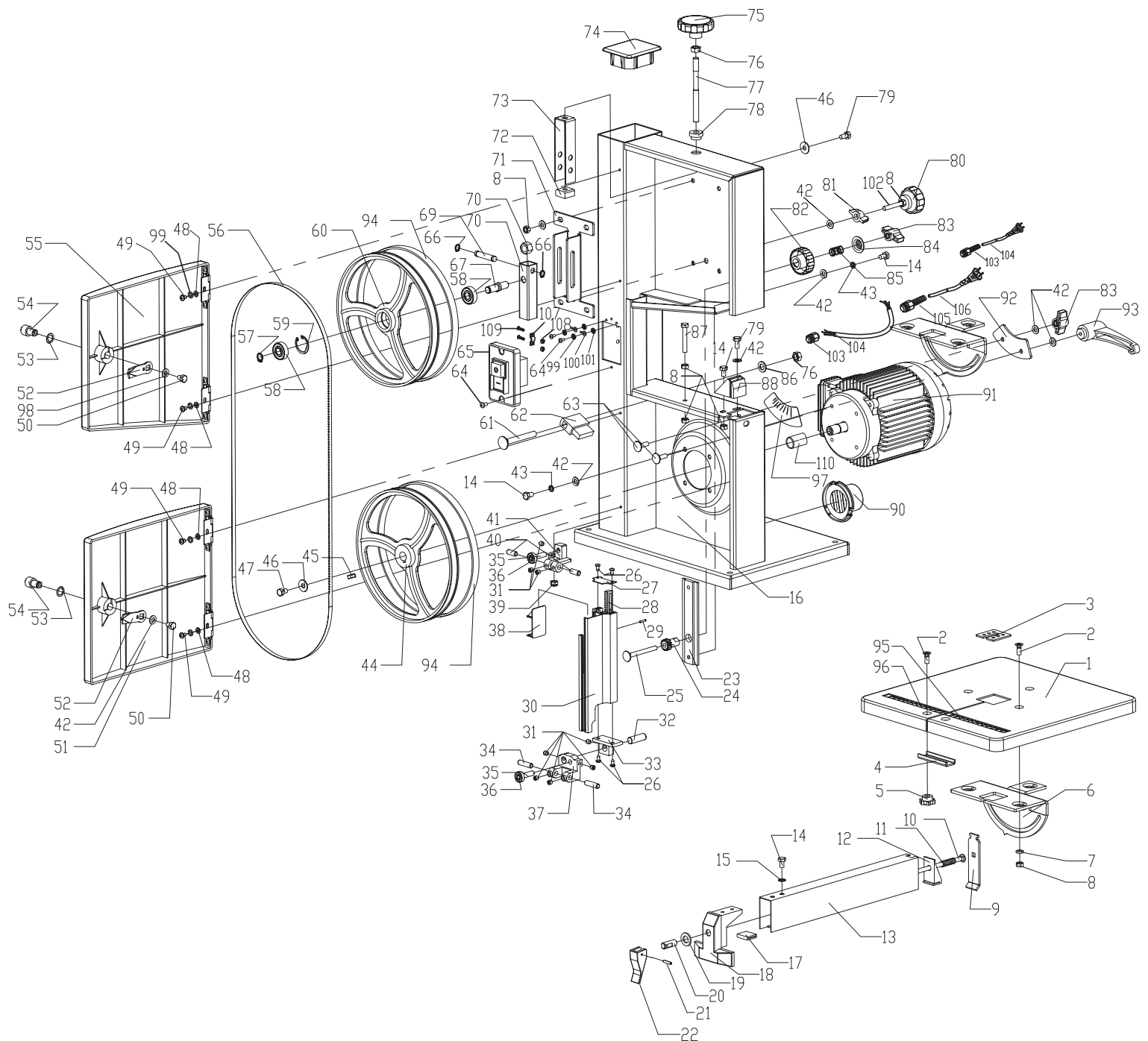

**Helpline: (023) 8049 4344. Sales Desk: (023) 8049 4333. General Enquiries: (023) 8026 6355.**

DRAPER TOOLS LTD, HURSLEY ROAD, CHANDLER'S FORD, EASTLEIGH, HANTS. SO53 1YF. U.K website: [www.drapertools.com](http://www.drapertools.com) e-mail: [sales@drapertools.com](mailto:sales@drapertools.com)

DKCH1115