

DRAPER[®]

STORMFORCE

INSTRUCTIONS FOR
900W 230V
Biscuit Jointer

Stock No.83611 Part No.PT8100SF

IMPORTANT: PLEASE READ THESE INSTRUCTIONS CAREFULLY TO ENSURE THE SAFE AND EFFECTIVE USE OF THIS PRODUCT.

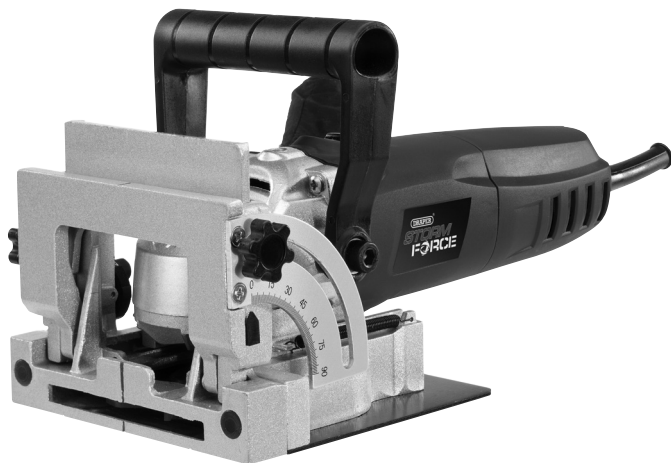

CE

DRAPER[®]

GENERAL INFORMATION

These instructions accompanying the product are the original instructions. This document is part of the product, keep it for the life of the product passing it on to any subsequent holder of the product. Read all these instructions before assembling, operating or maintaining this product.

This manual has been compiled by Draper Tools describing the purpose for which the product has been designed, and contains all the necessary information to ensure its correct and safe use. By following all the general safety instructions contained in this manual, it will ensure both product and operator safety, together with longer life of the product itself.

All photographs and drawings in this manual are supplied by Draper Tools to help illustrate the operation of the product.

Whilst every effort has been made to ensure the accuracy of information contained in this manual, the Draper Tools policy of continuous improvement determines the right to make modifications without prior warning.

1. TITLE PAGE

1.1 INTRODUCTION:

USER MANUAL FOR:

900W 230V BISCUIT JOINTER

Stock no. 83611

Part no. PT8100SF

1.2 REVISIONS:

Date first published March 2016

Revised July 2017

As our user manuals are continually updated, users should make sure that they use the very latest version.

Downloads are available from: <http://www.drapertools.com/manuals>

DRAPER TOOLS LIMITED
HURSLEY ROAD
CHANDLER'S FORD
EASTLEIGH
HAMPSHIRE
SO53 1YF
UK

WEBSITE: drapertools.com
PRODUCT HELP LINE: +44 (0) 23 8049 4344
GENERAL FAX: +44 (0) 23 8026 0784

1.3 UNDERSTANDING THIS MANUALS SAFETY CONTENT:

WARNING! Information that draws attention to the risk of injury or death.

CAUTION! Information that draws attention to the risk of damage to the product or surroundings.

1.4 COPYRIGHT © NOTICE:

Copyright © Draper Tools Limited.

Permission is granted to reproduce this publication for personal & educational use only.

Commercial copying, redistribution, hiring or lending is prohibited.

No part of this publication may be stored in a retrieval system or transmitted in any other form or means without written permission from Draper Tools Limited.

In all cases this copyright notice must remain intact.

2. CONTENTS

2.1 CONTENTS

	PAGE CONTENT	PAGE
1	TITLE PAGE	
	1.1 INTRODUCTION	2
	1.2 REVISION HISTORY	2
	1.3 UNDERSTANDING THIS MANUAL	2
	1.4 COPYRIGHT NOTICE	2
2	CONTENTS	
	2.1 CONTENTS	3
3	GUARANTEE	
	3.1 GUARANTEE	4
4	INTRODUCTION	
	4.1 SCOPE	5
	4.2 SPECIFICATION	5
	4.3 HANDLING & STORAGE	5
5	HEALTH & SAFETY INFORMATION	
	5.1 GENERAL SAFETY INSTRUCTIONS	6 - 7
	5.2 ADDITIONAL SAFETY INFORMATION FOR SAW BLADES	7 - 8
	5.3 CONNECTION TO THE POWER SUPPLY	8
6	TECHNICAL DESCRIPTION	
	6.1 IDENTIFICATION	9
7	UNPACKING & CHECKING	
	7.1 PACKAGING	10
	7.2 WHAT'S IN THE BOX?	10
8	BASIC BISCUIT JOINTER OPERATIONS	
	8.1 ON/OFF LOCKING SWITCH	11
	8.2 BLADE DEPTH SELECTION	11
	8.3 HEIGHT/ANGLE ADJUSTMENT	11
	8.4 BLADE REPLACEMENT	12
	8.5 CUTTING	12
	8.6 DUST EXTRACTION	12
9	MAINTENANCE	
	9.1 MAINTENANCE	13
10	OPTIONAL ACCESSORIES	
	10.1 OPTIONAL ACCESSORIES	14
11	EXPLANATION OF SYMBOLS	
	11.1 EXPLANATION OF SYMBOLS	15
12	DISPOSAL	
	12.1 DISPOSAL	16
	DECLARATION OF CONFORMITY	ENCLOSED

3. GUARANTEE

3.1 GUARANTEE

Draper tools have been carefully tested and inspected before shipment and are guaranteed to be free from defective materials and workmanship.

Should the tool develop a fault, please return the complete tool to your nearest distributor or contact Draper Tools Limited, Chandler's Ford, Eastleigh, Hampshire, SO53 1YF. England.

Telephone Sales Desk: (023) 8049 4333 or Product Help Line (023) 8049 4344.

A proof of purchase must be provided with the tool.

If upon inspection it is found that the fault occurring is due to defective materials or workmanship, repairs will be carried out free of charge. This guarantee period covering parts/labour is 12 months from the date of purchase except where tools are hired out when the guarantee period is 90 days from the date of purchase. The guarantee is extended to 24 months for parts only. This guarantee does not apply to normal wear and tear, nor does it cover any damage caused by misuse, careless or unsafe handling, alterations, accidents, or repairs attempted or made by any personnel other than the authorised Draper warranty repair agent.

Note: If the tool is found not to be within the terms of warranty, repairs and carriage charges will be quoted and made accordingly.

This guarantee applies in lieu of any other guarantee expressed or implied and variations of its terms are not authorised.

Your Draper guarantee is not effective unless you can produce upon request a dated receipt or invoice to verify your proof of purchase within the guarantee period.

Please note that this guarantee is an additional benefit and does not affect your statutory rights.

Draper Tools Limited.

4. INTRODUCTION

4.1 SCOPE

Professional style wood jointing for creating solid joints in soft & hard wood, ply board, MDF & most processed timbers. It is designed for domestic and light commercial use only. Any other application is considered misuse.

4.2 SPECIFICATION

Stock No.....	83611
Part No.....	PT8100SF
Motor:	
Rated voltage.....	230V~
Rated frequency	50Hz
Rated input	900W
Revolutions per minute (no load).....	11,000min ⁻¹
Blade:	
Diameter	100mm
Bore	22mm
Thickness	4.0mm
Teeth.....	6
Cutting depth.....	0-20mm
Angle adjustment.....	0-90°
Sound pressure level	87dB(A)
Sound power level	98dB(A)
Vibration level.....	2.7m/s ²
Weight (machine only)	3.2kg

4.3 HANDLING & STORAGE

Although this machine is small in size, care must still be taken when handling and lifting. Dropping this machine will have an effect on the accuracy and may also result in personal injury. This machine is not a toy and must be respected.

The environment will have a negative result on its operation if you are not careful. If the air is damp, components will rust. If the machine is unprotected from dust and debris; components will become clogged: And if not cleaned and maintained correctly or regularly the machine will not perform at its best.

5. HEALTH & SAFETY INFORMATION

5.1 GENERAL SAFETY INSTRUCTIONS

General Power Tools Safety Warnings

WARNING: Read all instructions. Failure to follow all instructions listed below may result in electric shock, fire and/or serious injury.

Save all warnings and instructions for future reference.

The term “power tool” in the warnings refers to your mains operated (corded) power tool or battery operated (cordless) power tool.

1) Work area safety

- a) **Keep work area clean and well lit.** Cluttered or dark areas invite accidents.
- b) **Do not operate power tools in explosive atmospheres, such as in the presence of flammable liquids, gases or dust.** Power tools create sparks which may ignite the dust or fumes.
- c) **Keep children and bystanders away while operating a power tool.** Distractions can cause you to lose control.

2) Electrical Safety

- a) **Power tool plugs must match the outlet.** Never modify the plug in any way. Do not use any adapter plugs with earthed (grounded) power tools. Unmodified plugs and matching outlets will reduce risk of electrical shock.
- b) **Avoid body contact with earthed or grounded surfaces such as pipes, radiators, ranges and refrigerators.** There is an increased risk of electric shock if your body is earthed or grounded.
- c) **Do not expose power tools to rain or wet conditions.** Water entering a power tool will increase the risk of electric shock.
- d) **Do not abuse the cord. Never use the cord for carrying, pulling or unplugging the power tool.** Keep cord away from heat, oil, sharp edges or moving parts. Damaged or entangled cords increase the risk of electric shock.
- e) **When operating a power tool outdoors, use an extension cord suitable for outdoor use.** Use of a cord suitable for outdoor use reduces the risk of electric shock.
- f) **If operating a power tool in a damp location is unavoidable, use a residual current device (RCD) protected supply.** Use of an RCD reduces the risk of electric shock.

3) Personal Safety

- a) **Stay alert, watch what you are doing and use common sense when operating a power tool. Do not use a power tool while you are tired or under the influence of drugs, alcohol or medication.** A moment of inattention while operating power tools may result in serious personal injury.
- b) **Use personal protective equipment. Always wear eye protection.** Protective equipment such as dust mask, nonskid safety shoes, hard hat, or hearing protection used for appropriate conditions will reduce personal injuries.
- c) **Prevent unintentional starting. Ensure the switch is in the off position before connecting to power source and/or battery pack, picking up or carrying the tool.** Carrying power tools with your finger on the switch or energising power tools that have the switch on invites accidents.
- d) **Remove any adjusting key or wrench before turning the power tool on.** A wrench or a key left attached to a rotating part of the power tool may result in personal injury.
- e) **Do not overreach. Keep proper footing and balance at all times.** This enables better control of the power tool in unexpected situations.
- f) **Dress properly. Do not wear loose clothing or jewellery. Keep your hair, clothing and gloves away from moving parts.** Loose clothes, jewellery or long hair can be caught in moving parts.

5. HEALTH & SAFETY INFORMATION

g) If devices are provided for the connection of dust extraction and collection facilities, ensure these are connected and properly used. Use of dust collection can reduce dust related hazards.

4) Power Tool Use And Care

- a) **Do not force the power tool. Use the correct power tool for your application.** The correct power tool will do the job better and safer at the rate for which it was designed.
- b) **Do not use the power tool if the switch does not turn it on and off.** Any power tool that cannot be controlled with the switch is dangerous and must be repaired.
- c) **Disconnect the plug from the power source and/or the battery pack from the power tool before making any adjustments, changing accessories, or storing power tools.** Such preventive safety measures reduce the risk of starting the power tool accidentally.
- d) **Store idle power tools out of the reach of children and do not allow persons unfamiliar with the power tool or these instructions to operate the power tool.** Power tools are dangerous in the hands of untrained users.
- e) **Maintain power tools. Check for misalignment or binding of moving parts, breakage of parts and any other condition that may affect the power tools operation. If damaged, have the power tool repaired before use.** Many accidents are caused by poorly maintained power tools.
- f) **Keep cutting tools sharp and clean.** Properly maintained cutting tools with sharp cutting edges are less likely to bind and are easier to control.
- g) **Use the power tool, accessories and tool bits etc., in accordance with these instructions, taking into account the working conditions and the work to be performed.** Use of the power tool for operations different from intended could result in a hazardous situation.

5) Service

- a. **Have your power tool serviced by a qualified repair person using only identical replacement parts.** This will ensure that the safety of the power tool is maintained.

5.2 ADDITIONAL SAFETY INSTRUCTIONS FOR SAW BLADES

Safe Working Practice

Maximum speed

- The maximum speed marked on the tool shall not be exceeded. Where stated, the speed range shall be adhered to.

Circular saw blades

- Circular saw blades, the bodies of which are cracked, shall be scrapped (repairing is not permitted).
- Composite (tipped) circular saw blades, where the tip dimension is reduced to less than 1mm, shall be taken out of service.

One piece tools

- Tools with visible cracks shall not be used.

Fastening of tools and tool parts

- Tools and tool bodies shall be clamped in such a way that they shall not loosen during operation.
- For tools with friction lock the positioning aid or setting gauge provided by the manufacturer shall be used to maintain radial and axial cutter projections.

5. HEALTH & SAFETY INFORMATION

- Care shall be taken when mounting tools to ensure that the clamping is by the hub of the tool and that the cutting edges are not in contact with each other or with the clamping elements.
- Fastening screws and nuts shall be tightened using the appropriate spanners, etc., and to the torque value provided by the manufacturer.
- Extension of the spanner or tightening using hammer blows shall not be permitted.
- Clamping surfaces shall be cleaned to remove dirt, grease, oil and water.
- Clamping screws shall be tightened according to instructions provided by the manufacturer. Where instructions are not provided, clamping screws shall be tightened in sequence from the centre outwards.
- Use of loose rings or bushes to “make up” bore sizes on circular saw blades shall not be permitted.
- Use of fixed rings, e.g. pressed or held by adhesive fixing, in circular saw blades or flanged bushes for other tools shall be permitted if made to the manufacturers specification.
- Resin shall only be removed from light alloys with solvents that do not affect the mechanical characteristics of these materials.

Repair of tools

- Repair of tools is only allowed according to the tool manufacturers instructions. Particular attention is drawn to the following.
- The design of composite (tipped) tools shall not be changed in the process of repair.
- Composite tools shall be repaired by a competent person, i.e. a person of training and experience, who has knowledge of the design requirements and understands the levels of safety to be achieved.
- Repair shall therefore include, e.g. use of spare parts which are in accordance with the specification of the original parts provided by the manufacturer.
- Tolerances which ensure correct clamping shall be maintained.
- For one piece tools care shall be taken that regrinding of the cutting edge will not cause weakening of the hub and the connection of the cutting edge to the hub.

5.3 CONNECTION TO THE POWER SUPPLY

Make sure the power supply information on the machine’s rating plate are compatible with the power supply you intend to connect it to.

This product comes supplied with a UK standard 3 pin plug fitted. It is designed for connection to a domestic power supply rated at 230V AC.

This appliance is Class II† and is designed for connection to a power supply matching that detailed on the rating label and compatible with the plug fitted.

If an extension lead is required, use an approved and compatible lead rated for this appliance. Follow all the instruction supplied with the extension lead.

†Double insulated : This product requires no earth connection as supplementary insulation is applied to the basic insulation to protect against electric shock in the event of failure of the basic insulation.

Apart from replacing the fuse in the plug, no other electrical work is recommended on this biscuit jointer.

6. TECHNICAL DESCRIPTION

6.1 IDENTIFICATION

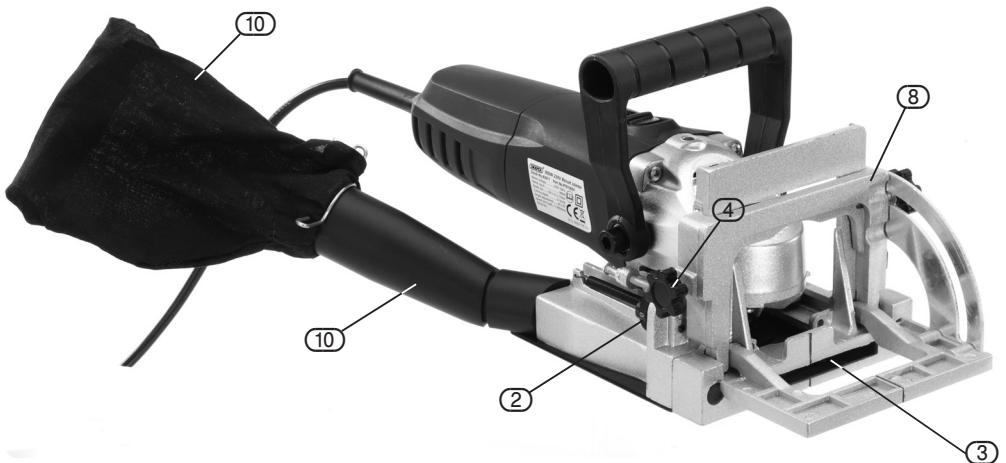
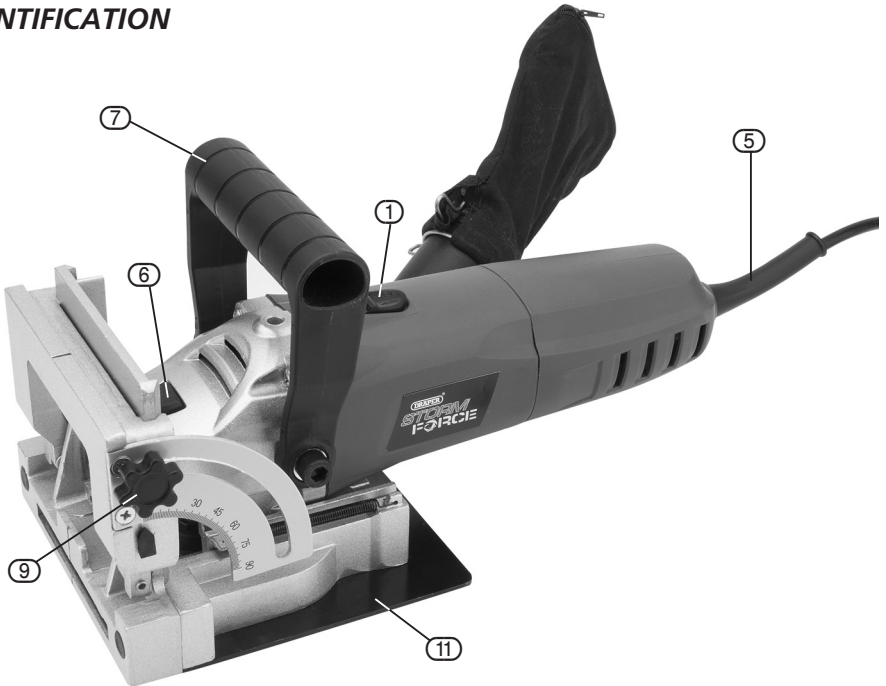

- | | |
|--|--|
| ① On/off switch. | ⑦ Auxiliary handle. |
| ② Depth selector. | ⑧ Front rest. |
| ③ Blade, inner and outer flanges (Fitted). | ⑨ Angle locking knob. |
| ④ Height locking knob. | ⑩ Dust collection bag and dust extraction chute. |
| ⑤ Plug and cable. | ⑪ Blade cover plate. |
| ⑥ Spindle lock. | |

7. TECHNICAL DESCRIPTION

7.1 PACKAGING

Carefully remove the biscuit jointer from the packaging and examine it for any sign of damage that may have happened during shipping. Lay the contents out and check them against the parts shown below. If any part is damaged or missing; please contact the Draper Help Line (the telephone number appears on the Title page) and do not attempt to use the biscuit jointer.

The packaging material should be retained at least during the guarantee period: in case the machine needs to be returned for repair.

Warning! Some of the packaging materials used may be harmful to children. Do not leave any of these materials in the reach of children.

If any of the packaging is to be thrown away, make sure they are disposed of correctly; according to local regulations.

7.2 WHAT'S IN THE BOX?

As well as the biscuit jointer; there are several parts not fitted or attached to it.

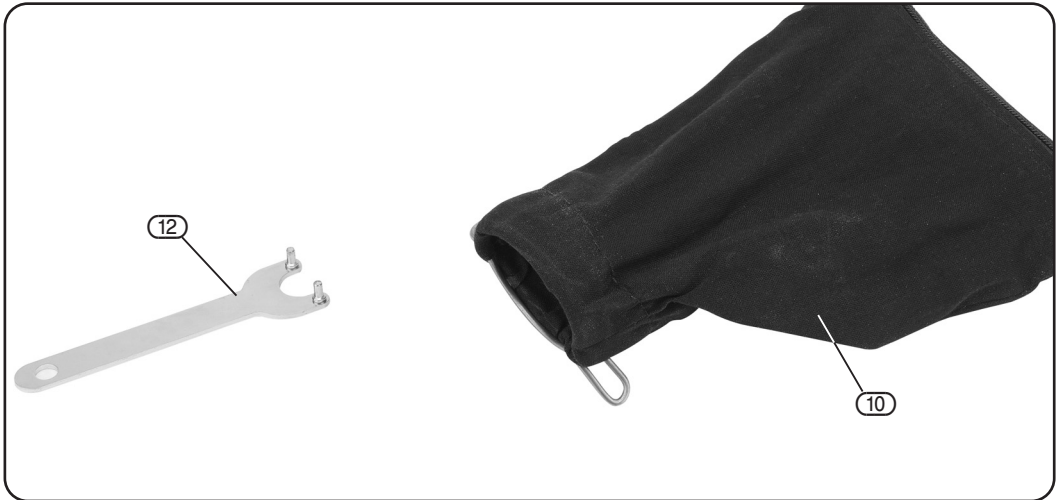

⑩ Dust collection bag

⑫ Pin spanner

8. BASIC BISCUIT JOINER OPERATIONS

IMPORTANT: Make sure that the mains voltage matches the voltage stated on the machines rating plate.

NOTE: Remove the plug from the socket before carrying out adjustment, servicing or maintenance.

8.1 ON/OFF LOCKING SWITCH – FIG. 1

To switch the biscuit joiner "ON" push the switch button ① towards the front of the machine.

Pushing it all the way forward will cause the button to lock in place, for extended use.

To release the switch, press the back half of the button in towards the machine body.

The switch will disengage and spring back to the "OFF" position.

NOTE: Before plugging the Biscuit Joiner in, ensure the switch is NOT locked in the "ON" position.

8.2 BLADE DEPTH SELECTION – FIG. 2

The biscuit joiner has three depth settings which are selectable using knob ② and indicated by arrow ②.1.

The three standard settings correspond to the three standard sizes of biscuits available:

0 = No.0 Biscuits.

10 = No.10 Biscuits.

20 = No.20 Biscuits.

NOTE: This biscuit joiner has a fourth setting (M).

This depth is the maximum depth capacity of the machine and is only possible with a new blade fitted and backing out the fine adjustment screw. This setting will not be necessary for most biscuit jointing operations and it is recommended that the operator use only the 0, 10, 20 settings.

8.3 HEIGHT/ANGLE ADJUSTMENT – FIG. 3

The position and angle of the biscuit can be set up using the guide.

Loosen both levers ④ ⑨ and slide front rest ⑧ up or down to adjust the height. Lock with both levers ④ ⑨.

The angle is also adjustable by loosening lever ⑨. Tilt the front rest ⑧. Use the guide scale to indicate the angle between 0-90°. When set, lock lever ⑨.

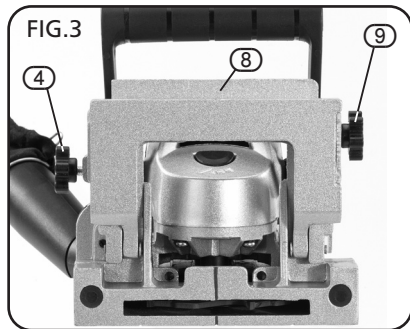
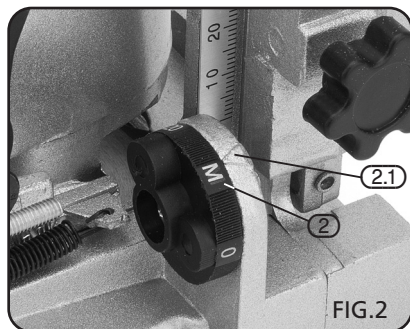

8. BASIC BISCUIT JOINER OPERATIONS

NOTE: Remove the plug from the socket before carrying out adjustment, servicing or maintenance.

8.4 BLADE REPLACEMENT – FIGS. 4 -5

Set the height adjustment (4) to maximum to avoid hindrance.

Remove the four screws (11.2) and cover plate (11).

Press the spindle lock button (6) and turn the machine over to gain access to the underside.

Loosen and remove the blade flange (14) using the pin spanner (12) provided.

Pass the blade out through the exposed base section.

NOTE: When installing a new blade ensure it is correct to the direction of rotation. The biscuit joiner rotates clockwise when viewed from above and the tip of the blade should appear on the right of the each tooth.

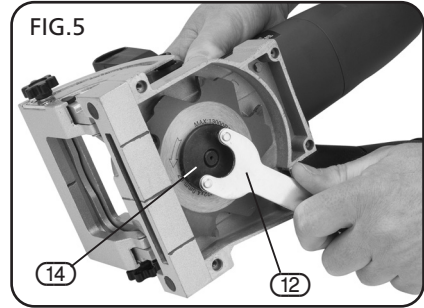
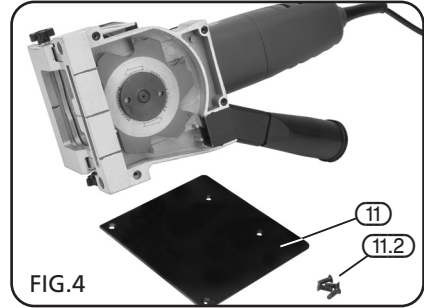

8.5 CUTTING – FIG. 6

When the setup has been completed, position the joiner up to the workpiece. For reference there are two marks on the front cover plate which indicates the horizontal centre of the blade (3), and vertical centre of the blade (3.5). When aligned and the biscuit size is set, switch on the machine and make the cut.

Switch off after use.

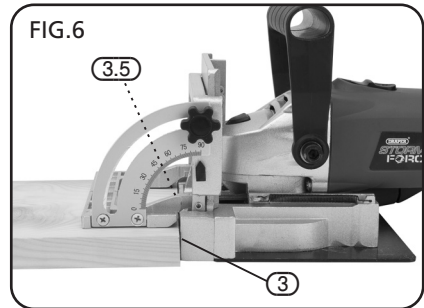

8.6 DUST EXTRACTION – FIG. 7

The Biscuit Joiner is equipped with a dust bag (10) which should be used at all times to reduce the amount of airborne dust particles.

Suitable protective equipment should also be worn.

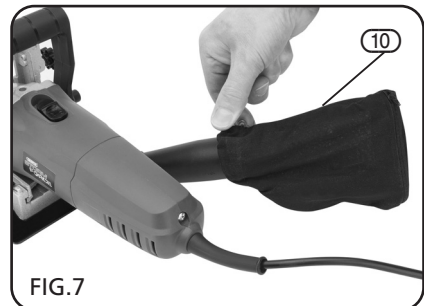

9. MAINTENANCE

9.1 MAINTENANCE

NOTE: Remove the plug from the socket before carrying out adjustment, servicing or maintenance.

The biscuit jointer does not require any special maintenance. Regularly clean/vacuum the ventilation slots. Use only a mild cleaner and a damp cloth to clean the tool.

10. OPTIONAL ACCESSORIES

Contact your local Draper Stockist for further details.

SPARE BLADES:

Stock No.78458

SPARE JOINTING BISCUITS:

Stock No.	Part No.	Item	Quantity
07260	APT82E	0	100 (approx.)
07259	APT82E	10	100 (approx.)
07258	APT82E	20	100 (approx.)
07261	APT82E	*Assorted	100 (approx.)

11. EXPLANATION OF SYMBOLS

11.1 EXPLANATION OF SYMBOLS



Warning!
Wear dust mask.



Warning!
Read the instruction manual



Warning!
Wear suitable eye/face
protection.



Warning!
Wear ear defenders.



WEEE
Do not dispose of Waste Electrical
& Electronic Equipment in with
domestic rubbish



Class II construction
(Double insulated).

12. DISPOSAL

12.1 DISPOSAL

- At the end of the machine's working life, or when it can no longer be repaired, ensure that it is disposed of according to national regulations.
- Contact your local authority for details of collection schemes in your area.

In all circumstances:

- Do not dispose of power tools with domestic waste.
- Do not incinerate.
- Do not abandon in the environment.
- Do not dispose of WEEE* as unsorted municipal waste.



* Waste Electrical & Electronic Equipment.

- **DRAPER TOOLS LIMITED,**
Hursley Road, Chandler's Ford,
Eastleigh, Hampshire. SO53 1YF. U.K.
- **Help Line:** (023) 8049 4344
- **Sales Desk:** (023) 8049 4333
- **General Enquiries:** (023) 8026 6355
- **Service/Warranty Repair Agent**
For aftersales servicing or warranty repairs, please
contact the Draper Tools Help Line for details of an
agent in your local area.

YOUR DRAPER STOCKIST

RDCH0717

